

### Description:

10/100/1000 Base-T 2x1 RJ45, with Integrated Magnetics and with or without LEDs. Designed to support such applications as: LAN-on-Motherboard (LOM) and PC applications



### Features and Benefits:

- Ⓜ RoHS-5 peak wave solder temperature rating 235°C
- Ⓜ RoHS-6 peak wave solder temperature rating 260°C
- Ⓜ LAN interface suitable for 10/100/1000Base-T applications
- Ⓜ 2x1 RJ45 design saves on PCB real estate
- Ⓜ RJ45 connection meets CAT3, 5e & 6 Fast Ethernet performance standard

### Electrical Performance Summary:

- Ⓜ Meets IEEE 802.3 specification
- Ⓜ High performance for maximum EMI suppression
- Ⓜ Minimum 1500Vrms isolation per IEEE 802.3 requirement

### Electrical Specifications @ 25°C — Operating Temperature 0°C to +70°C

RoHS-5 <sup>3</sup> Compliant Part No.	RoHS-6 <sup>4</sup> Compliant Part No.	LEDs	Turns <sup>1,2</sup> Ratios		Insertion Loss TX/RX (dB MAX)	Return Loss @ 100Ω ±15Ω (dB TYP)			Crosstalk (dB MIN)			Common Mode Rejection (dB TYP)		Hipot (Vrms) (MIN)
			L / R	TX		RX	1-65 MHz	1-10 MHz	30 MHz	60-80 MHz	1-10 MHz	32-60 MHz	60-100 MHz	
JC0-0019	JC0-0019NL	—	1CT:1	1CT:1	-1.0	-20	-16	-12	-40	-35	-30	-30	-20	1500
—	JC0-0063NL	G,Y / G,Y	1CT:1	1CT:1	-1.0	-20	-16	-12	-40	-35	-30	-30	-20	1500

#### NOTES:

1. Both transmit and receive channels meet IEEE 802.3 specifications.
2. Different electrical specifications can be accommodated. For more information, please contact Pulse.
3. **RoHS-5** - Product does not contain 5 out of the 6 banned substances specified in the RoHS directive. Product contains lead in applications considered as solders.
4. **RoHS-6** - Product does not contain 5 out of the 6 banned substances specified in the RoHS directive. Some internal connections may contain lead in high temperature solder (solder alloys containing more than 85% lead).

### RJ45 Durability Testing Rating

Part Number	Mating Force (MAX)	Unmating Force (MAX)	Durability	Plug to Jack Retention (MIN)
JC Series	5lbs./2.268kgs.	5lbs./2.268kgs.	500 Insertions	20lbs./9.072kgs.

### RJ45 Material Specification

Part Number	Shield		Contact			Housing	
	Material	Finish	Material	Plating Area	Solder Area	Material	Specification
JC Series	Brass	20-40μ inches thick nickel over brass	Phosphor Bronze	15μ inches gold over 30-80μ inches nickel	75-300μ inches tin-lead over 75-300μ inches bright nickel	Thermoplastic	UL 94 V-0

Notes: Connector dimensions comply with FCC dimension requirements.

### Mechanical

JC0-0019 / JC0-0019NL

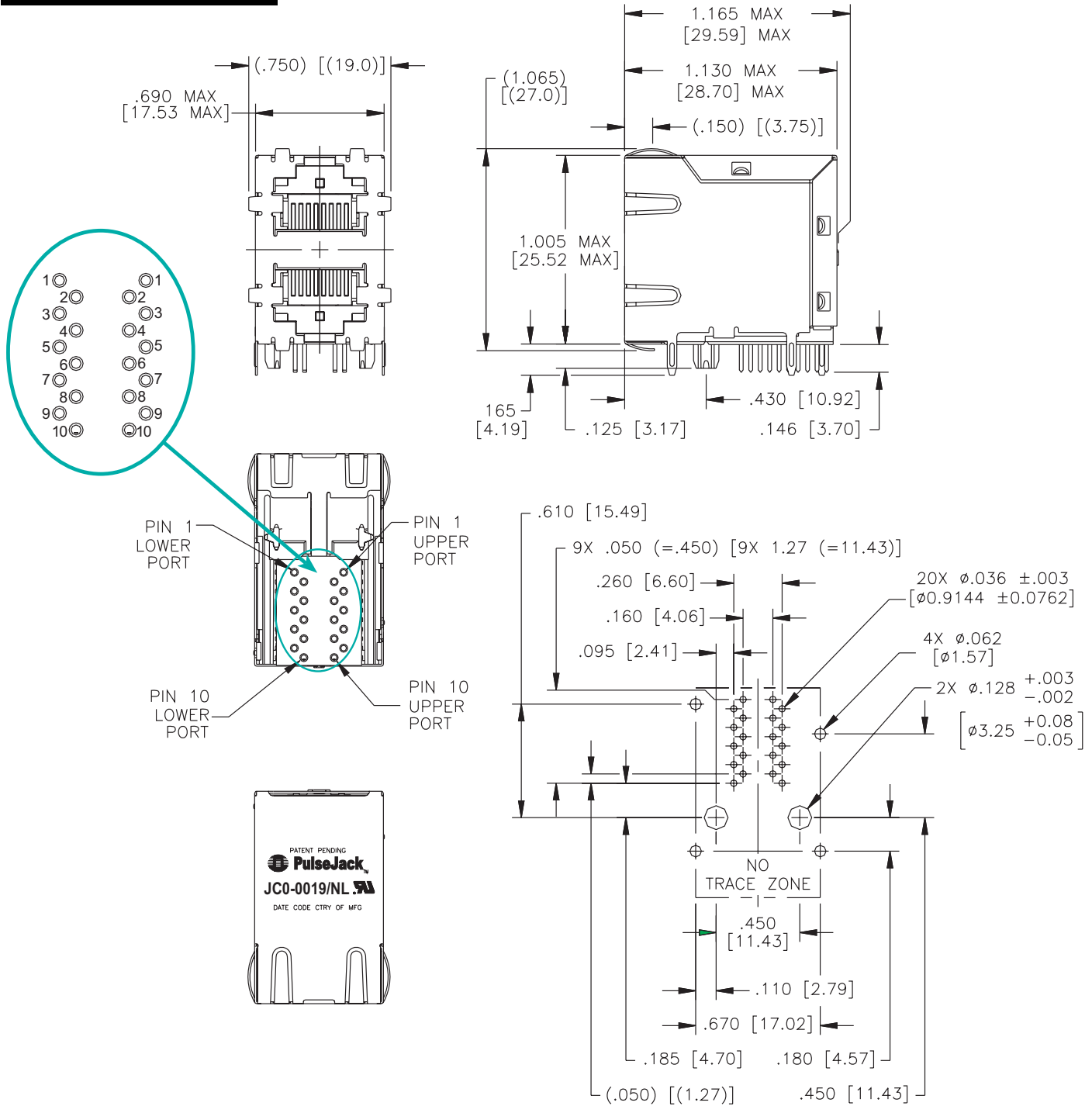

Weight ..... .8.1 grams  
Tray ..... .45/tray

SUGGESTED PC BOARD LAYOUT VIEWED FROM COMPONENT SIDE  
UNLESS OTHERWISE SPECIFIED DIMENSIONAL TOLERANCE IS  $\pm .002$

### Mechanical

**JC0-0063NL**

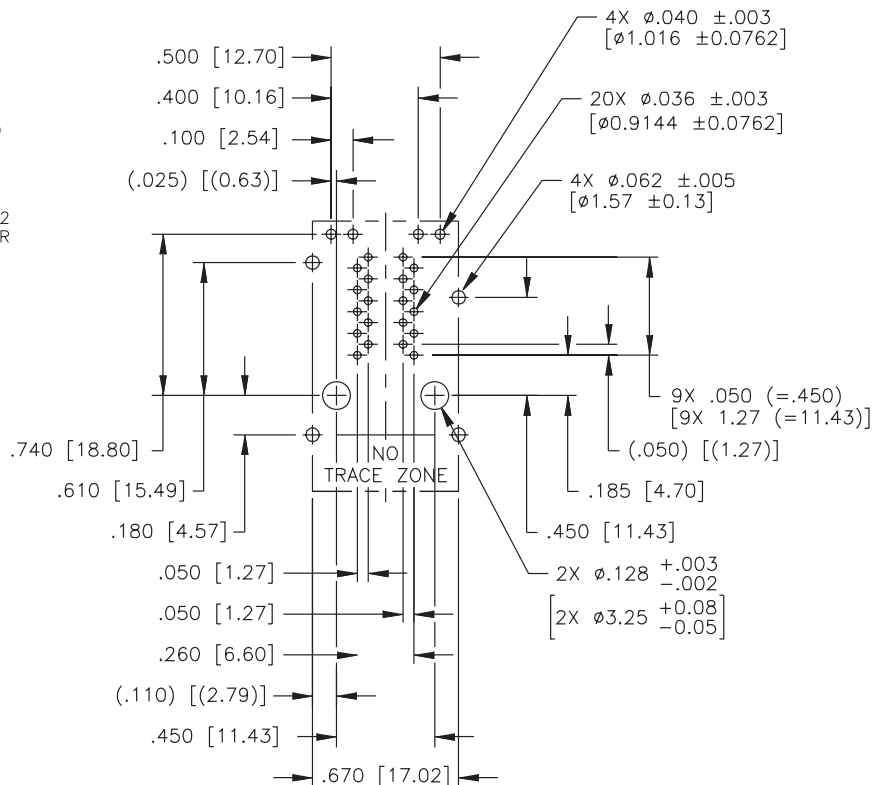
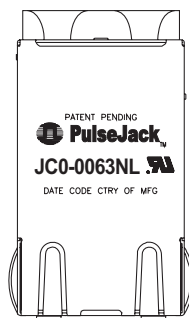
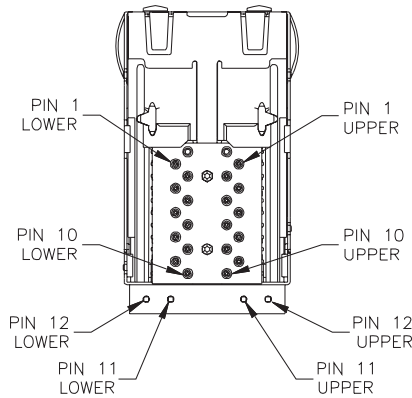
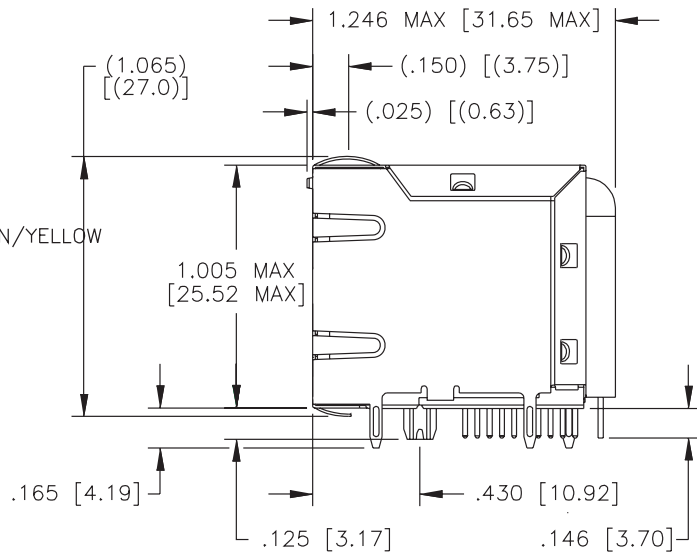
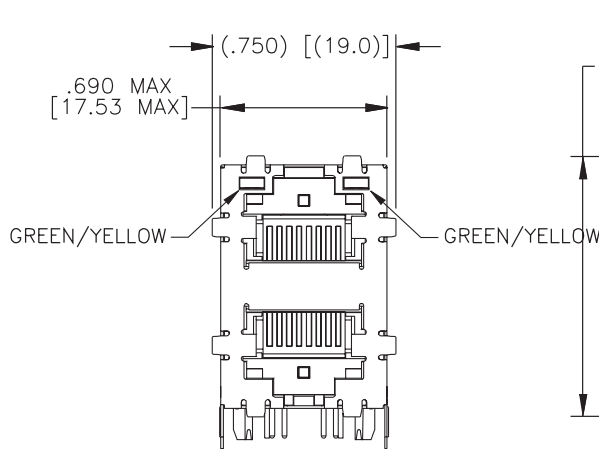

Weight ..... .81 grams  
Tray ..... .45/tray

SUGGESTED PC BOARD LAYOUT VIEWED FROM COMPONENT SIDE  
UNLESS OTHERWISE SPECIFIED DIMENSIONAL TOLERANCE IS  $\pm 0.002$

## Schematic

JC0-0019 / JC0-0019NL / JC0-0063NL

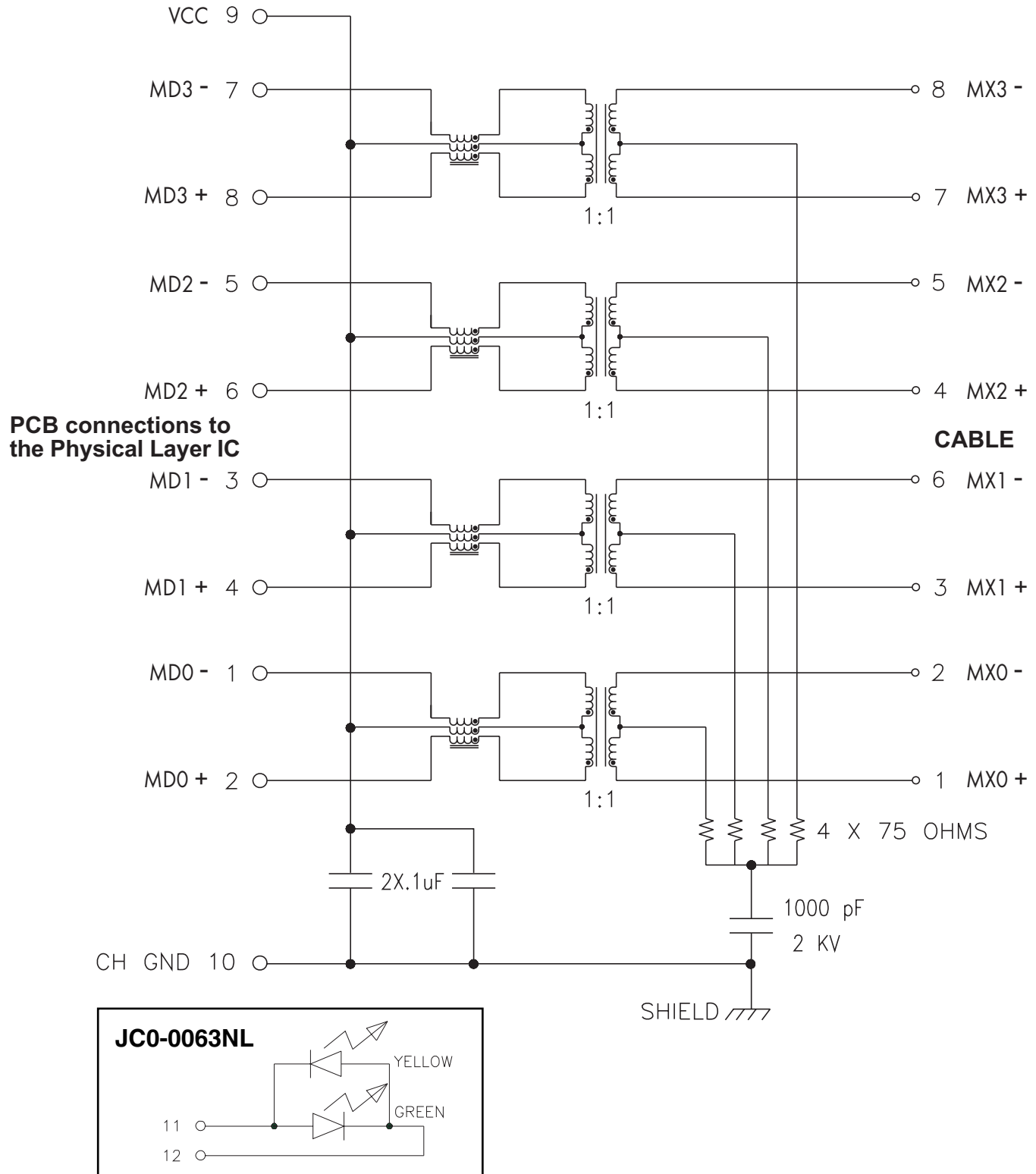

### Application Circuit

JC0-0019 / JC0-0019NL

10/100/1000  
IC PHY

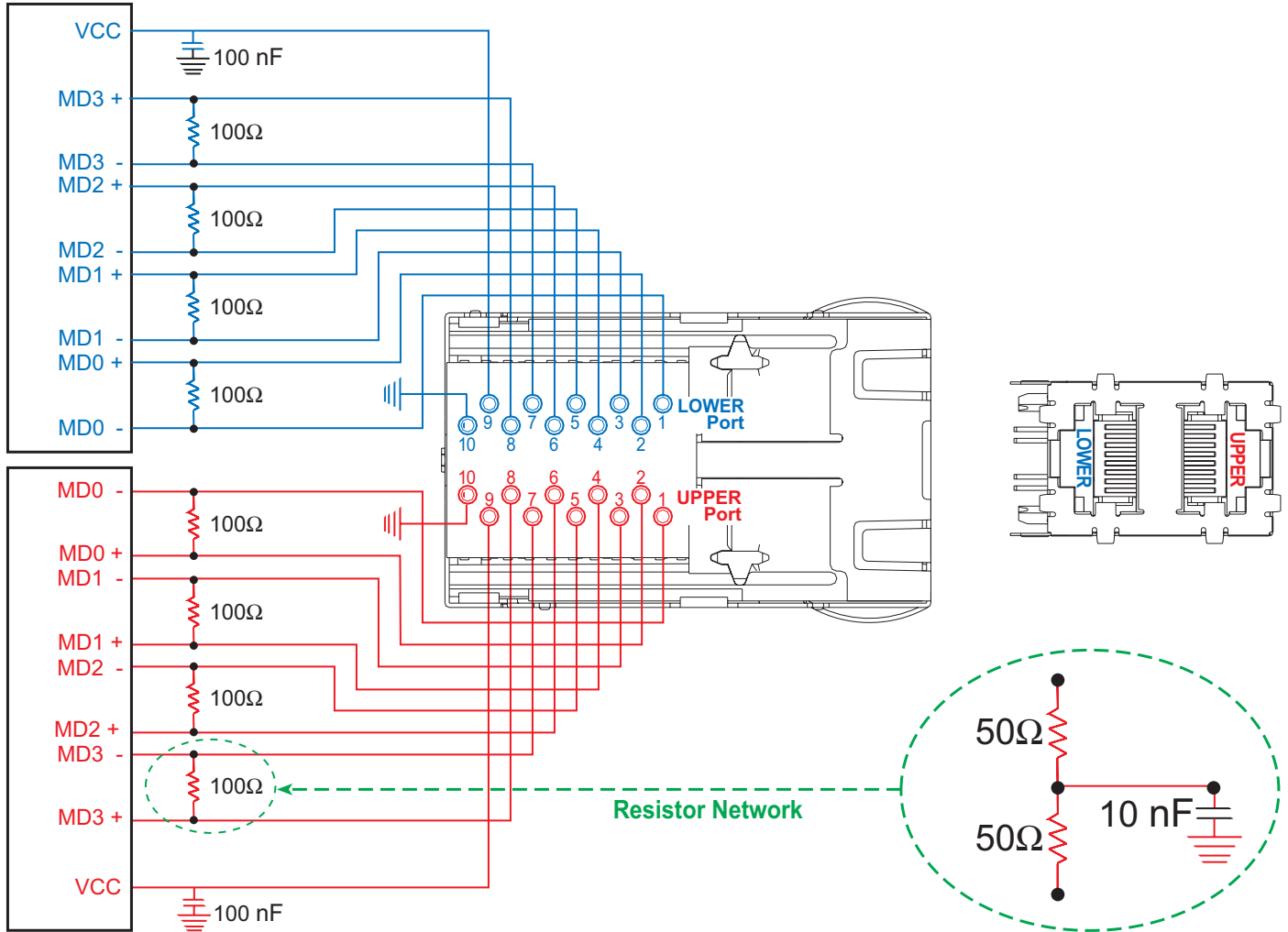

#### PCB Layout Recommendations:

1. For maximum EMI suppression (electromagnetic interference) place the decoupling capacitors adjacent to Vcc and 50Ω connections.
2. Connections to ground should be as short as possible.
3. Connections between the 10/100/1000 IC and the connector should be direct (ideally no change in direction) and of minimum length.

#### For More Information:

##### Pulse Worldwide Headquarters

12220 World Trade Dr.  
San Diego, CA 92128  
U.S.A.  
[www.pulseeng.com](http://www.pulseeng.com)

Tel: 858 674 8100  
Fax: 858 674 8262

##### Pulse Europe

Einsteinstrasse 1  
D-71083 Herrenberg  
Germany

Tel: 49 7032 7806 0  
Fax: 49 7032 7806 12

##### Pulse China Headquarters

B402, Shenzhen  
Tech-Innovation International  
Tenth Kejinan Rd.  
High-Tech Industrial Park  
Nanshan District, Shenzhen  
China

Tel: 86 755 33966678  
Fax: 86 755 33966700

##### Pulse North China

Room 1503  
XinYin Building  
No. 888 YiShan Rd.  
Shanghai 200233  
China

Tel: 86 21 54643211/2  
Fax: 86 21 54643210

##### Pulse South Asia

150 Kampong Ampat  
#07-01/02  
KA Centre  
Singapore 368324

Tel: 65 6287 8998  
Fax: 65 6280 0080

##### Pulse North Asia

No. 26  
Kao Ching Rd.  
Yang Mei Chen  
Taoyuan Hsien  
Taiwan, R. O. C.

Tel: 886 3 4641811  
Fax: 886 3 4641911

Performance warranty of products offered on this data sheet is limited to the parameters specified. Data is subject to change without notice. Other brand and product names mentioned herein may be trademarks or registered trademarks of their respective owners. © Copyright, 2007. Pulse Engineering, Inc. All rights reserved.